

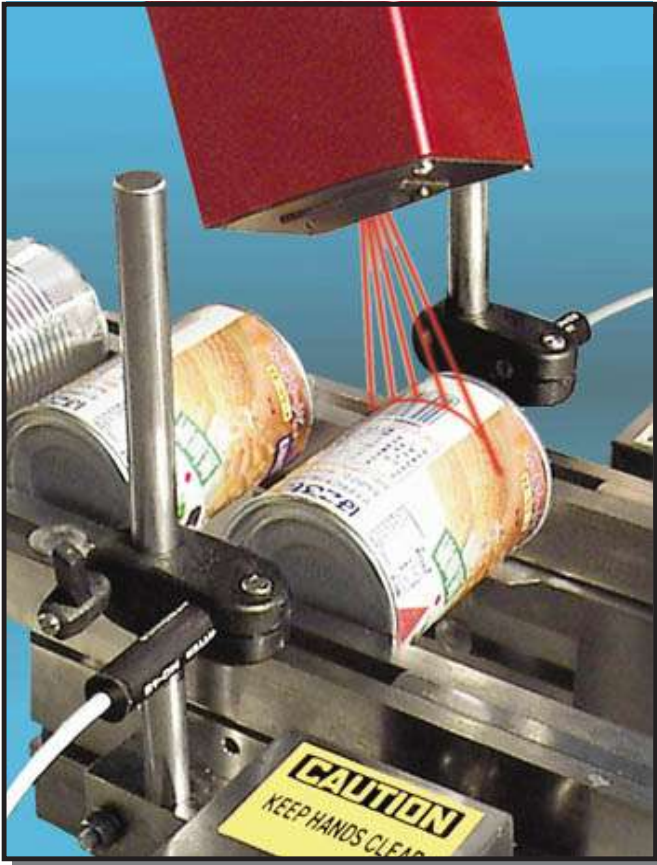

illumitronics

Model 545-B Bar code / label inspection system



The 545-B is the only fully integrated bar code / label inspection and reject system available for "Roll Through" labeling lines.

The 545-B verifies each bar code and compares it to the master code in memory. If a code does not match the master code, is unreadable or missing, the 545-B removes the product from the production line.

The system will provide complete inspection on glass, plastic, composite and metal containers at line speeds up to 100 inches per second. The 545-B is installed into your production line directly downstream from all Mateer-Burt, Newway and Bear labeling machines.

The system will reject the following labeling defects.

- Missing Labels
- Twisted Labels
- Flapping Labels
- Dog-Eared Labels
- Unreadable Bar Codes
- Mis-Match Bar Codes
- Code Grades C, D & F
- Increase Production
- Reduce Customer Complaints
- Increased Quality
- Reduce Consumer Complaints
- Reduced Handling Cost
- Full bar code & label inspection
- Reduced Material Handling
- Container sizes up to 13 inches in height and 7 inches in dia.



illumitronics

specifications

Drawing shown indicates left to right hand operation.
Unit is also available for right to left hand operation.

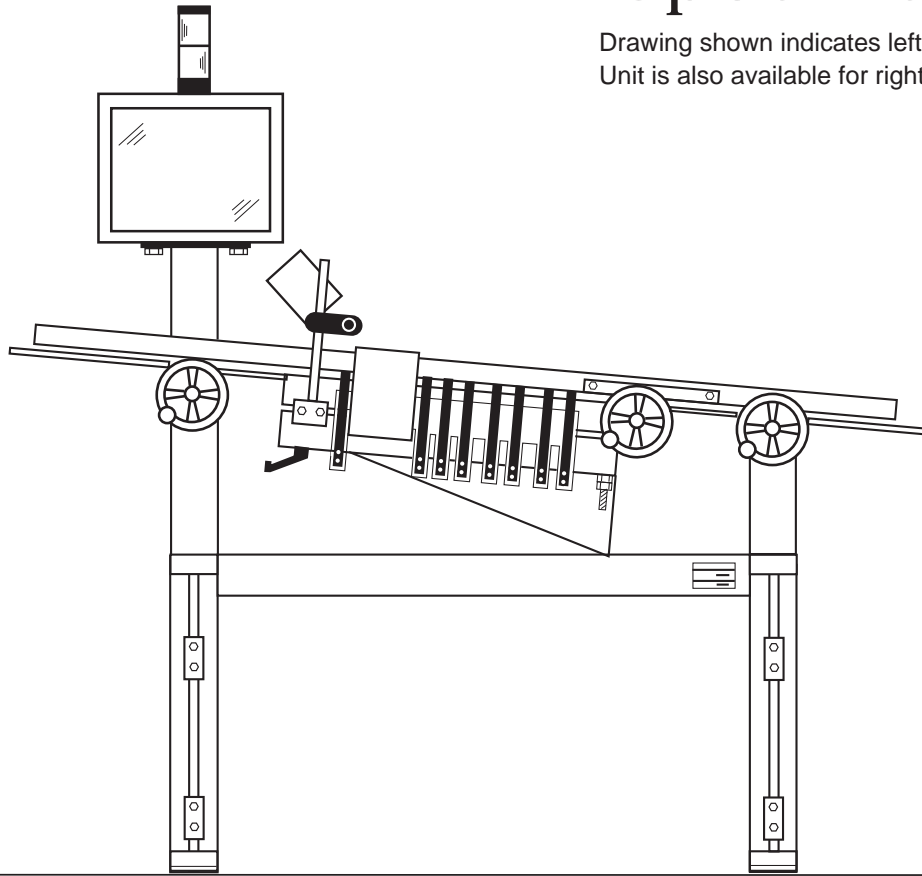

Model 545-B Bar code / label inspection system

Maximum Line Speed:...	1,200 cpm (100 inch/second)	Reject Codes.....	Mismatch, Unreadable, Grade D, Grade F
Container Sizes.....	13 inches tall / 7 inches diameter max. Fully Adjustable	Electronics.....	Component Logic
Container Types.....	Steel, Aluminum, Plastic, Composite & Glass	Reject System.....	2 electric driven solenoids 8 Reject Blades
Label Types.....	Paper, Foil, Plastic, Lithograph	NEMA Rating.....	1,2,3,4,12 & 13
Power Requirements...	110 VAC / 50 - 60 hz / Single Phase	Overall Height.....	63 in / min - 77 in / max
Inspection System.....	Labels: Infrared Fiber Optic / Visible Cross Beam	Track Height.....	33 in / min - 47 in / max
Inspection System.....	Bar Codes: 640nm diode laser	Overall Length.....	62.000 in
Bar Code Types.....	UPC-A, UPC-E, EAN-8, EAN-13, Code128 Interleaved 2 of 5, Code 93, Codabar, Code 3 of 9	Frame Length.....	42.500 in
Passing Codes.....	Match-Code, Grade A, Grade B, Grade C	Overall Width.....	19.750 in
		Operational Weight.....	260 lbs
		Paint.....	Electro-Static Powder Coat